

ASSA ABLOY is the global leader in door opening solutions, dedicated to satisfying end-user needs for security, safety and convenience



Please Note:

This document is provided as a dimensional reference and should not be printed as a drilling template unless it can be correctly scaled to 100% by your printer.

ASSA ABLOY Australia Pty Limited
235 Huntingdale Road,
Oakleigh Victoria, 3166
Australia

info.au@assaabloy.com
assaabloy.com.au

ASSA ABLOY New Zealand Ltd.
6 Armstrong Road
Albany, North Shore City, 0632
New Zealand

info.nz@assaabloy.com
assaabloy.co.nz

Power Size	Max. Door Width	Max. Door Weight	Max. Door Opening	Min. Closing Torque	Number Turns
EN1	750mm	20kg	175°	9Nm	1
EN2	850mm	40kg	175°	13Nm	2
EN3	950mm	60kg	175°	18Nm	4*
EN4	1100mm	80kg	175°	26Nm	6
EN5	1250mm	100kg	175°	37Nm	9
EN6	1400mm	120kg	175°	54Nm	13

* - Factory default setting

**SINGLE DOOR
(RIGHT HAND DOOR PULL SIDE)**

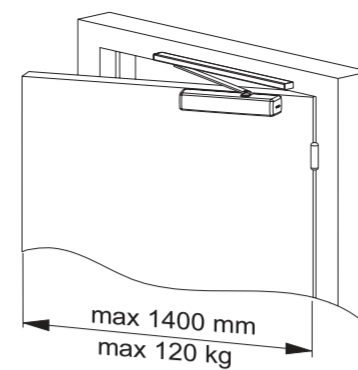

2516EMC SERIES ELECTROMECHANICAL HOLD OPEN DOORCLOSER

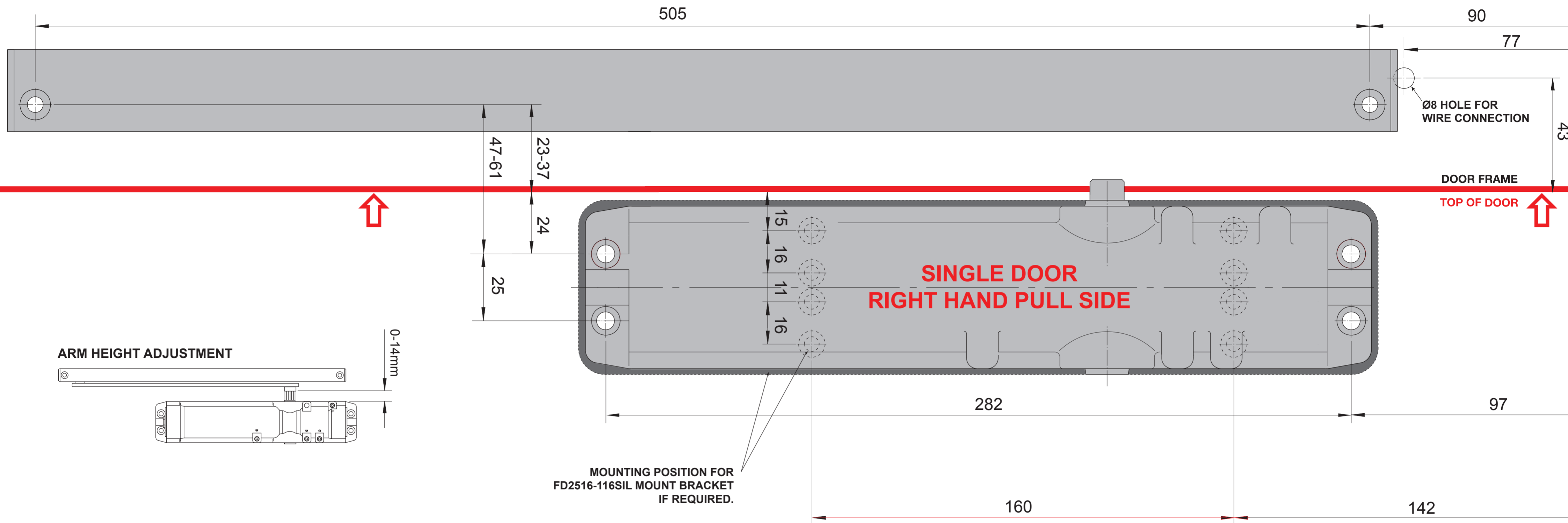

USE THIS TEMPLATE IN CONJUNCTION WITH THE 2516EMC INSTALLATION INSTRUCTION (SUPPLIED)

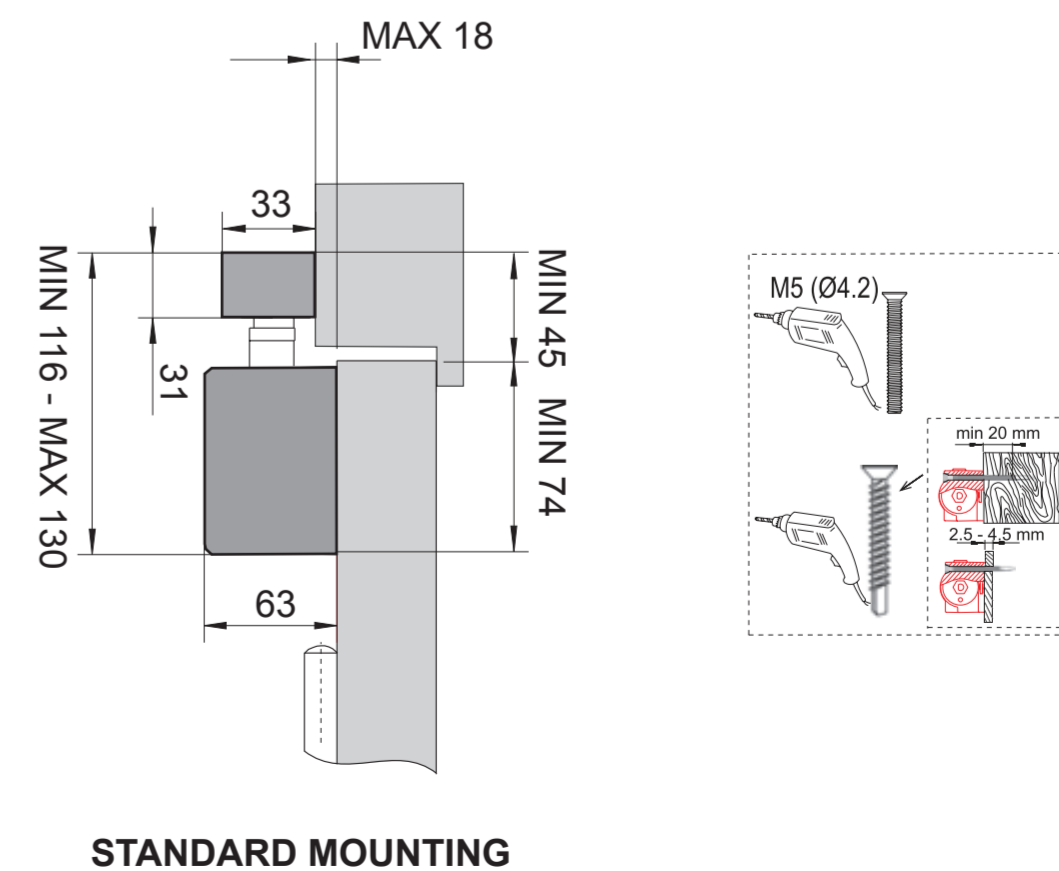
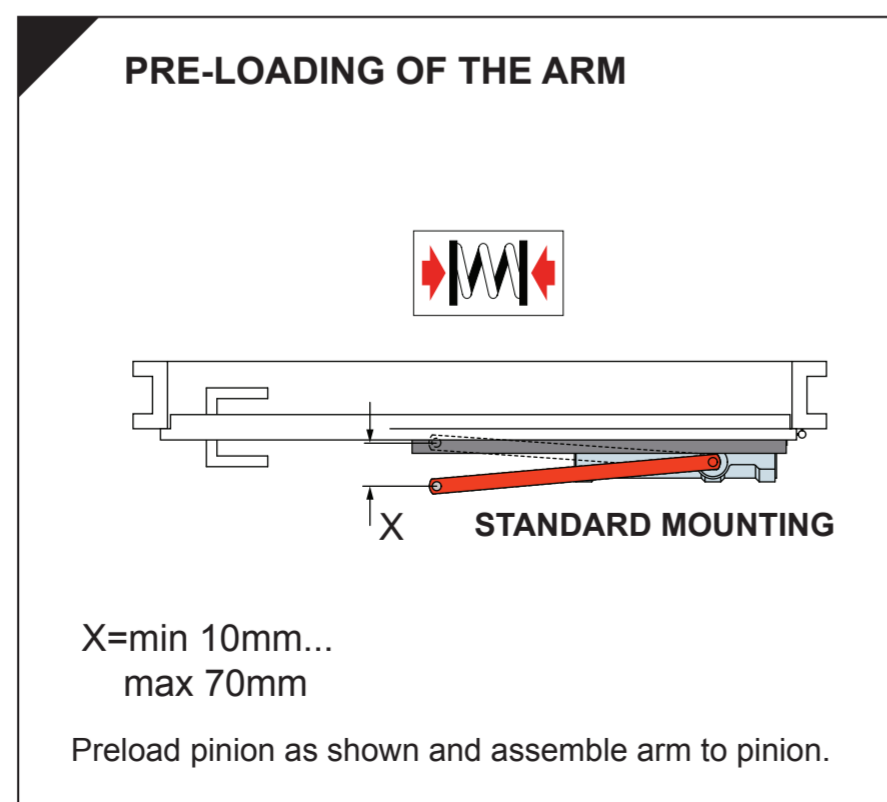
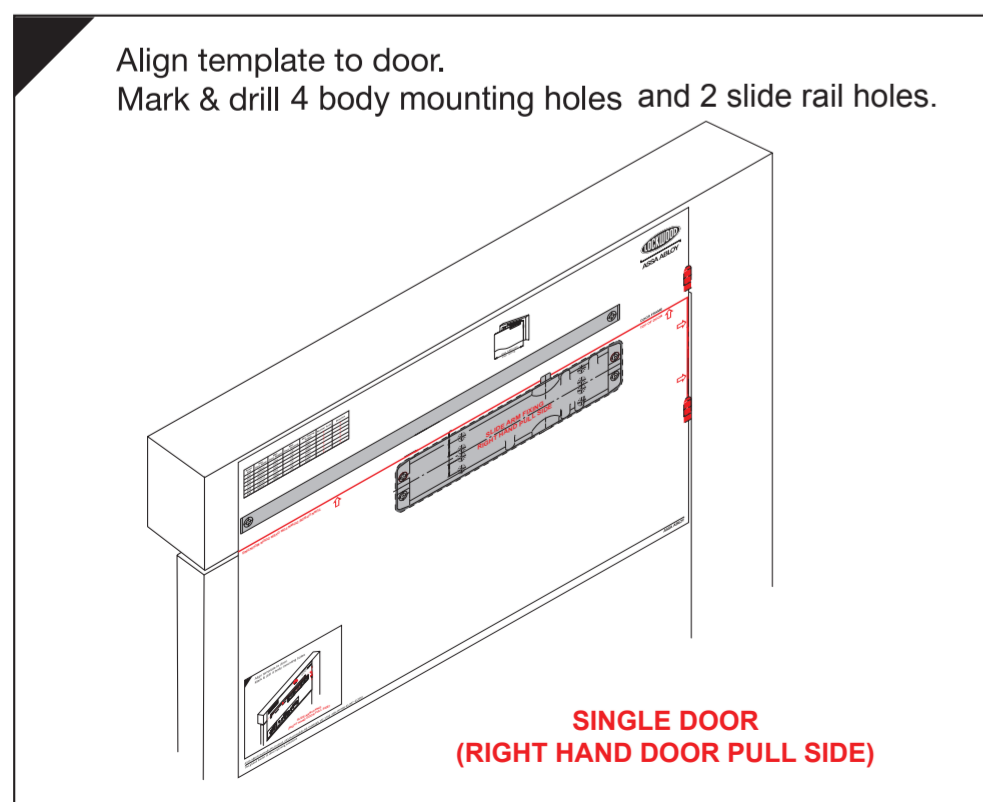

PART No. 2516EMC-221 Iss. A 1011